

Camden Glass Works

Bill Lockhart, Beau Shriever, Carol Serr, and Bill Lindsey

The Camden Glass Works was in business for less than one decade. Its primary product appears to have been fruit jars, although the plant made also beer bottles and other containers. The business might have had a bright future if it had not become embroiled in a patent infringement case that heralded its demise.

History

Camden Glass Works, Camden, New Jersey (1875-1884)

Joseph Wharton opened the Camden Metal Works in 1862 between 10th St. and Cooper's Creek. Later called the American Nickel Works, it was the only nickel refinery in the United States at that time. Wharton's production was primarily aimed at coins, specifically the five cent "nickel." In 1875, he purchased the adjoining property to the north (10th & State Streets) and opened the Camden Glass Works (Camden 2010; Yates 1987:170).

The report that accompanied the 1877 Hexamer General Surveys map (Volume 12) stated that the Camden Glass Works was entirely rebuilt in 1876. The factory was just north of the American Nickel Works, and Joseph Wharton owned both properties. The Nickel Works employed 80 workers, only two of whom were boys. However, boys made up half of the 60 workers at the glass plant. The glass factory was made of brick and had a single furnace surrounded by five annealing ovens.

By at least March 2, 1882, Joseph Wharton advertised that the Camden Glass Works was "mfrs. of Green & Colored Glass, Hollow-ware, Genuine Mason Fruit Jars." The plant was located at 10th & State streets at Camden, but Robert R. Haydock was the "Selling Agent" at 75 Murray St. in New York. The firm advertised "a new patented fruit jar entitled 'The Advance'" on May 24, 1883 (quoted in Roller 1997). Thomas G. Otterson of Philadelphia was the inventor of the jar closure, although he did not receive his patent until September 18, 1883 – four months after Camden Glass first advertised the jar. Otterson assigned half the patent rights to Joseph

Wharton, the proprietor of the Camden Glass Works. (see Patent section below). The firm extensively advertised both the Advance and Mason's Improved jars throughout 1884.

Wilson and Caperton (1994:70) recorded all beer bottle advertising in *The Western Brewer* between 1883 and 1890 as well as samples from issues between 1878 and 1882. The Camden Glass Works only advertised beer bottles for a single year between August 1883 and August 1884. An 1884 ad listed "Fruit Jars, Mason P.L., Mason Improved, and the Advance," and the plant was doing well as of May 15 (Roller 1997). While it is unclear how much the company depended on fruit jars sales, it was the finishing of these fruit jars that led to the closure of the works by the end of the year.

Wharton was embroiled in a suit initiated by the Cohansey Glass Mfg. Co. over the use of a glass-grinding machine based on the Kelly & Samuel patent of 1869 (National Reporter System 1886:189). In mouth-blown jars with screw threads, the threads were formed in the mold. The jar was then wetted, burst, or broken off from the blowpipe, and the rim of the finish was ground flat. The Kelly & Samuel invention provided a mechanical means to accomplish the grinding (see Patent section).

Thomas Hipwell patented a similar "Glass-Grinding Machine" in 1876 that used a similar grinding surface but had a different method of holding the jars in place and turning them during the grinding operation. The Cohansey lawyers averred that the Camden Glass Works had modified its Kelly & Samuel machines in such a way as to infringe on the Hipwell grinding machine patent. There was no question that the machines had been modified. The question was whether those modifications violated the later patent. The court passed judgement in favor of Cohansey, apparently causing the demise of the Camden Glass Works (National Reporter System 1886:189-192).

The timing requires a bit of speculation. The court passed judgement on May 14, 1886, apparently two years after the closing of the Camden Glass Works. It is possible that the court had instructed Camden Glass to cease use of the machines pending a court ruling. If so, the burden of hand grinding, downtime to remove the machines, fines imposed by the court, or some combination of these may have been sufficient to create the demise of the firm.

The March 26, 1885, issue of *Crockery & Glass Journal* noted that the Camden Glass Works had “not been in blast this season” (Roller 1997). Although the firm was listed in the directory as late as 1885, it is virtually certain that the plant closed in late 1884 (Pepper 1971:170). The 1890 Hexamer General Surveys map (Volume 24) still showed the glass works, but they were listed as idle.

Patents

The Otterson Patents of 1883, 1884, and 1885

Thomas G. Otterson of Philadelphia applied for a patent for a “Jar-Fastener” on March 31, 1883. He received Patent No. 285,062 on September 18 of the same year (Figure 1). Otterson assigned half of the patent to Joseph Wharton. Wharton advertised the new jar – *The Advance* – by at least May 24 – less than two months after Otterson applied for the patent. The patent drawing showed a glass lid held in place by a spring-loaded clamp that tightened by engaging a continuous thread (in Otterson’s words, “spirally arranged beads or threads”) molded into the finish of the jar.

Otterson may have foreseen the collapse of the Camden Glass Works. While still at Philadelphia, he collaborated with John H. Otterson (possibly a brother) to produce a “Cap or Cover for Jars or Cans.” The Ottersons applied for a patent on June 12, 1884, and received Patent No. 308,571 on November 25 of that year. Significantly, they did *not* assign the patent to anyone else. Although the Ottersons never referenced the previous invention, and the new lid and jar finish showed distinct changes, it is clear from the patent drawings and the actual jars that the 1884 patent was inspired by and improved on the 1883 patent (see the Woodbury section for more information about the later patents and jars).

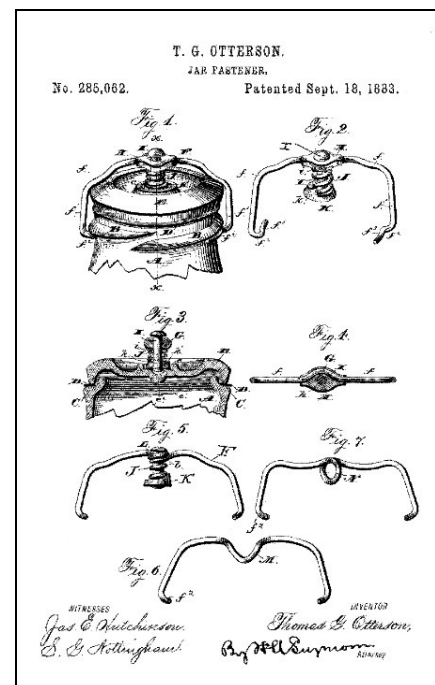

Figure 1 – Otterson’s 1883 patent

Otterson apparently withdrew from the firm about the time of the collapse and moved to Woodbury, New Jersey. There, he conspired with Cornelius C. Voorhees and applied for a patent for a “Glass Can-Cap” on December 29, 1884. The pair received Patent No. 313,229 on March 3, 1885 – an obvious improvement on the November 25, 1884 patent. This was the prototype for the Woodbury Glass Works jars that bear the “WOODBURY” name¹ and, usually, a WGW monogram that appears to have been inspired by the JW monogram – thus possibly devised by Otterson.

Kelly & Samuel, 1869

The Camden Glass Works apparently used the grinding machine invented by Kelly & Samuel. On December 28, 1869, Alexander W. Kelly and John B. Samuel, both of Philadelphia, received Patent No. 98,270 for an “Improvement in Machine for Grinding Glass Jars” (Figure 2). John was apparently related to A.R. Samuel, the owner of the Keystone Glass Works of Philadelphia – one of the other users of the Kelly & Samuel machine. According to the court records, Wharton had made some modifications to the machine that infringed on the Hipwell patent (see below).

Thomas Hipwell, 1876

If Otterson’s patent set the Camden Glass Works in motion, another, earlier patent was its undoing. On March 13, 1876, Thomas Hipwell applied for a patent for an “Improvement in Glass Grinding-Machines.” He received

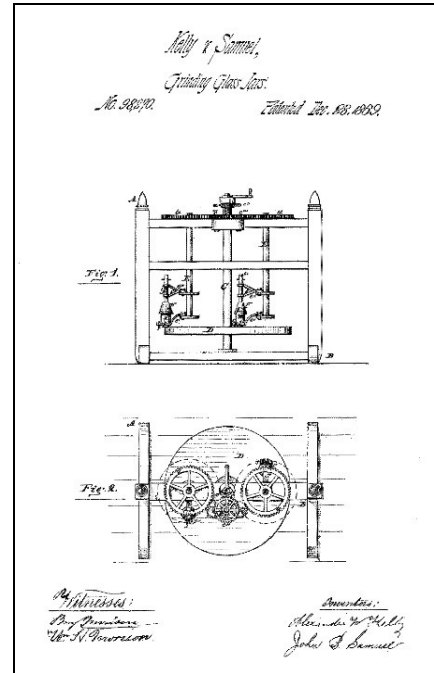

Figure 2 – Kelly & Samuel’s 1869 patent

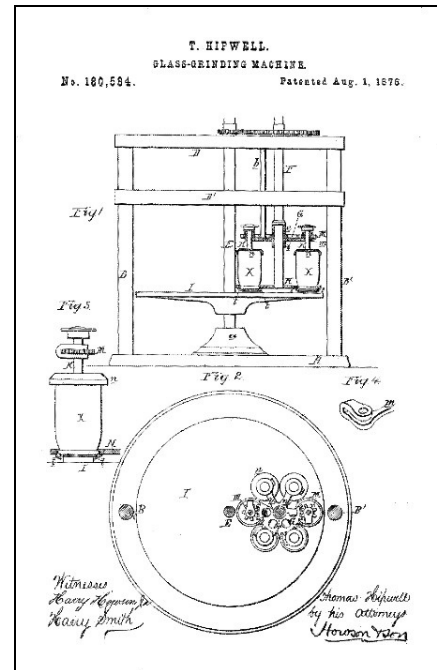

Figure 3 – Hipwell’s 1876 patent

¹ These jars should not be confused with the pressed, milk (opal) glass cold cream jars made for Woodbury Soap Co., maker of Woodbury Cold Cream.

Patent No. 180,584 on August 1 of the same year (Figure 3). He assigned the patent to the Cohansey Glass Mfg. Co. Hipwell's invention greatly simplified grinding the rims of fruit jars with continuous-thread finishes.

Alexander W. Kelly, 1882

Although the device apparently played no part in the altercation between the Cohansey Glass Mfg. Co. and the Camden Glass Works, Alexander W. Kelly applied for another "Glass-Grinding Machine" patent on February 25, 1882. He received Patent No. 266,840 on October 31 of the same year (Figure 4). This was apparently an improvement over both the Kelly & Samuel 1869 device and the Hipwell 1876 machine.

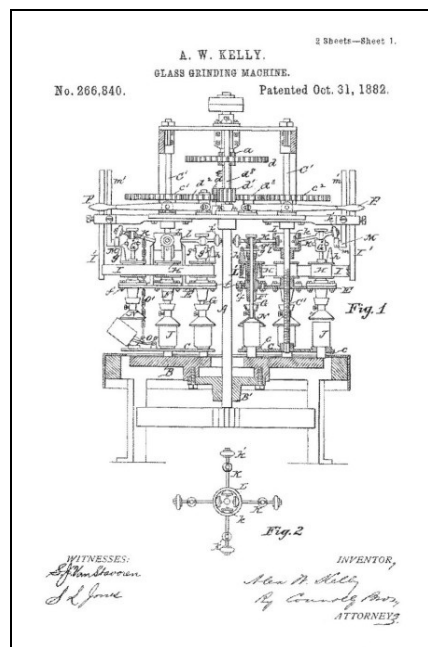

Figure 4 – Kelly's 1882 patent

Containers and Marks

It is likely that the Camden Glass Works used no mark during its earliest years – except for its full name on some soda bottles. There is a remote chance that Camden Glass used the C.G.W. logo that has been found on Union (strap-sided) flasks, Hutchinson soda bottles, beer bottles, and Turlington Balsam bottles.² However, it is *much* more likely that the Clyde Glass Works made most or all of those (see the section on Clyde Glass Works for a complete discussion).

ADVANCE (1883-1884)

Toulouse (1969:14-15) illustrated and described the earliest variation of the Advance jars. The front of the jar was embossed "TRADE MARK (arch) / ADVANCE through a JW monogram (horizontal) / PAT. APL'D FOR (inverted arch)" on the front body (Figures 5-7). Each jar was mouth blown with a ground rim. Toulouse did not know the maker.

² Turlington bottles were some of the earliest embossed medicine bottles, first used in 1774. Their use continued for centuries. See Rawlinson (1969) for more information.

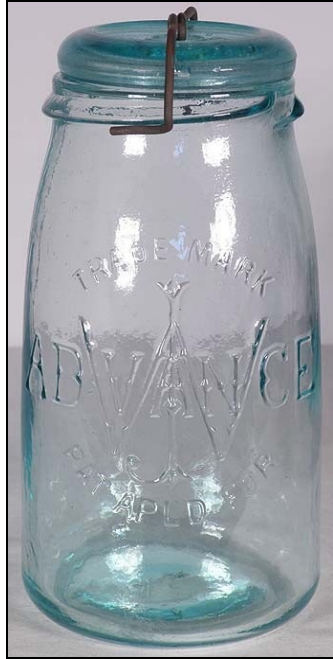

Figure 5 – Advance Jar (North American Glass)

Roller (1983:354) added a second variation. This jar was identical, except that the last line was now “PAT SEPT 18, 1883.” He dated the jars ca. 1883-1886 and noted the Camden Glass Works as the manufacturer. Creswick (1987:3) added that the pint sizes in both variations were made with two “different outside mouth measurements . . . 2 1/8” (Midget), and 2 1/2” (Regular mouth). The patent document illustrated four different clamp styles that could be used with the lids. One had a simple coil in the center of the wire, and this was apparently the one selected by Camden Glass for its jars (Figure 8).

Another had a bend in the wire that affected the pressure, and the final two were more complex, each with a coiled spring affixed to the wire clamp. Creswick noted that some of the lids had centers that were “too depressed for the clamp with the coil.” She hypothesized that one of the other clamps was used for these.



Figure 6 – Lid of Advance Jar (North American Glass)



Figure 7 – Finish of Advance Jar (North American Glass)

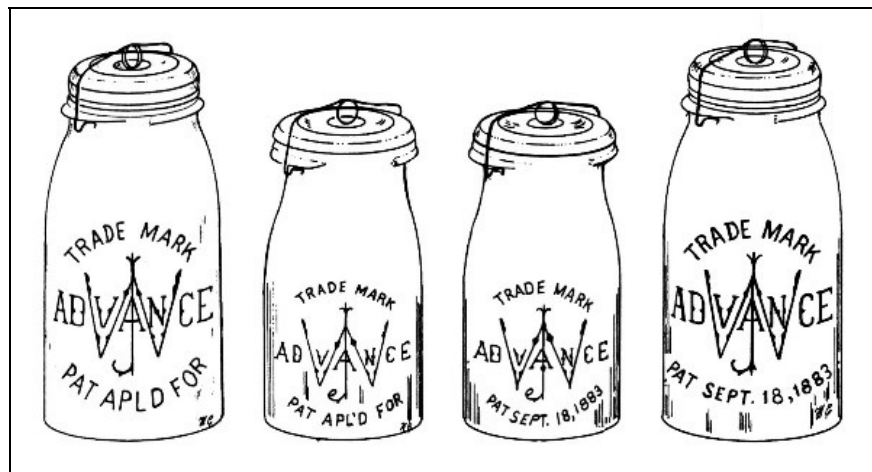

Figure 8 – Variations in Advance Jars (Creswick 1987:3)

Leybourne (2008:4) added the missing link – a jar with “PAT SEPT 18, 1883” embossed over a ghosted “PAT. APL’D FOR.” This was only found on the quart size. Creswick (1987:3) also suggested that the jars were made by the Woodbury Glass Works, but there is no indication that her identification was correct. She almost certainly swayed by the connections of both glass houses to Thomas Otterson.

Roller (1883:354) listed two variations of lids, both embossed on the top:

1. * ADVANCE FRUIT JAR * PATENT SEP 18, 1883
2. TRADE ADVANCE (through JW monogram) MARK

Creswick (1987:3) added a lid that had the depression in the center but no embossing and disagreed slightly as to the placement of the embossing on one lid. Since Roller (2011) agreed with the earlier Roller study, we have maintained that description above.

Each of these variations had a very short manufacturing history. The one embossed “PAT. APL’D FOR” was probably only made during 1883. Once the patent was received, the bottom line was peened out and replaced with “PAT SEPT 18, 1883.” Both the ghosted variation and the dated jar were almost certainly made during late 1883 and all of 1884.

CAMDEN GLASS WORKS

“CAMDEN GLASS WORKS” was embossed in an arch on the sides at least four blob-top soda bottles, all used in the New Jersey/eastern Pennsylvania area (Figure 9). The name of the bottler was embossed on the opposite side on two of these bottles. All had pontil scars on the bases (von Mechow 2014). Unless this plant was open much earlier than we have discovered, this is fairly late for pontiled bottles.



Figure 9 – CAMDEN GLASS WORKS (von Mechow 2014)

Discussion and Conclusions

Both the Advance jar and the full glass house name are clear indicators of Camden Glass Works products. Because the plant was short lived after the invention of the jars, the “ADVANCE” embossing forms an almost perfect chronological marker for dating sites. The pontil scars on the bottles embossed with the full factory name, however, do not fit well with the generally accepted dates for the discontinuance of the use of pontil rods – typically not used after the 1860s, almost completely phased out by the early 1870s (Lindsey 2014).

The wording on the report with the 1877 Hexamer General Survey Map *may* be significant. The report said that the glass works had been rebuilt in 1877. If the factory was originally constructed in 1876, this seems very soon for a rebuilding. It is thus likely that either the wording is incorrect or that the original plant was built earlier. We have only one source (as secondary source at that) giving the opening date of 1876. With current information, however, neither wording nor the pontil scars can be resolved.

Acknowledgments

As always, we wish to thank Doug Leybourne for allowing us to use the drawings from the Alice Creswick books and Greg Spurgeon for granting permission to use the photos from North American Glass.

Sources

Camden, New Jersey

2010 “Industrialization.” Camden, New Jersey/
<http://www.ci.camden.nj.us/history/industrialization.html>

Creswick, Alice

1987 *The Fruit Jar Works, Vol. I, Listing Jars Made Circa 1820 to 1920's*. Douglas M. Leybourne, N. Muskegon, Michigan.

Hexamer, Ernest

1877 "Hexamer General Surveys: American Nickel Works; Camden Glass Works." Vol. 12. <http://www.philageohistory.org/rdic-images/view-image.cfm/HGSv12.1086-1087>

1890 "Hexamer General Surveys: American Nickel Works; Camden Glass Works." Vol. 24. <http://www.philageohistory.org/rdic-images/view-image.cfm/HGSv24.2344-2345>

Leybourne, Douglas M.

2008 *The Collector's Guide to Old Fruit Jars: Red Book 10*. Privately published, North Muskegon, Michigan.

Lindsey, Bill

2014 "Historic Glass Bottle Identification & Information Website."
<http://www.sha.org/bottle/index.htm>

National Reporter System

1886 *The Federal Reporter: Cases Argued and Determined in the Circuit and District Courts of the United States, May-August 1886*. Vol. 27. West Publishing, St. Paul, Minnesota.

Pepper, Adeline

1971 *Glass Gaffers of New Jersey*. Scribner's Sons, New York.

Roller, Dick

1983 *Standard Fruit Jar Reference*. Acorn Press, Paris, Illinois.

1997 "Camden, NJ History Notes." Dick Roller files.

2011 *Standard Fruit Jar Reference: 2010 Update*. Edited by Jerome McCann and Barry Bernas. Fruit Jar Annual/Phoenix Press, Chicago.

Toulouse Julian Harrison

1969 *Fruit Jars*. Thomas Nelson & Sons, Camden, New Jersey.

von Mechow, Tod

2014 “Soda & Beer Bottles of North America: Bottle Attributes - Beer & Soda Bottle Manufacturers.” <http://www.sodasandbeers.com/SABBottleManufBeerSoda.htm>

Wilson, John P. and Thomas J. Caperton

1994 “Fort Selden, New Mexico: Archaeological Investigations of the Latrines and Magazine, 1974-1976.” *The Artifact* 32(2-4):i-ix,1-145).

Yates, W. Ross

1987 *Joseph Wharton: Quaker Industrial Pioneer*. Associated University Press, Cranbury, New Jersey.

Last updated 2/21/2014