

F. SCHEIDT.
MACHINE FOR FORMING THE NECKS OF GLASS BOTTLES.

APPLICATION FILED OCT. 21, 1903.

NO MODEL.

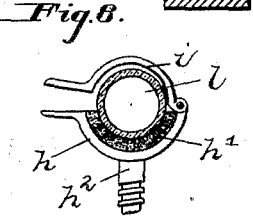
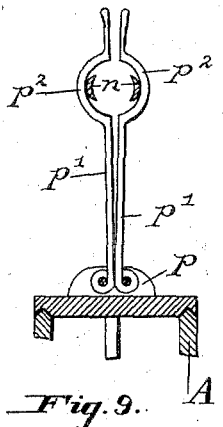
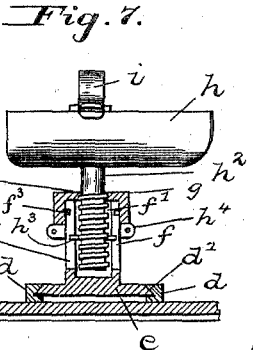
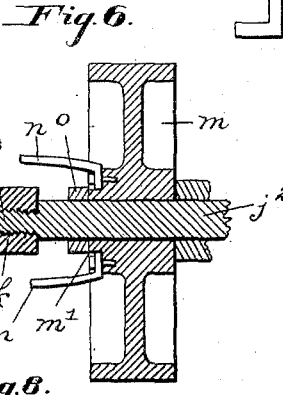
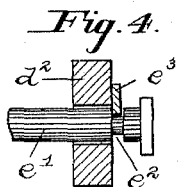
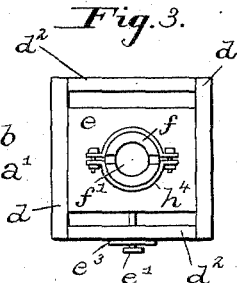
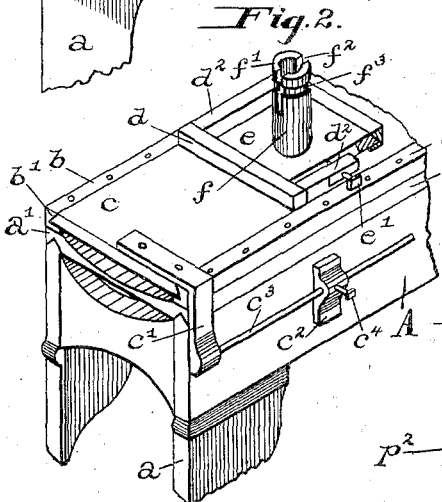
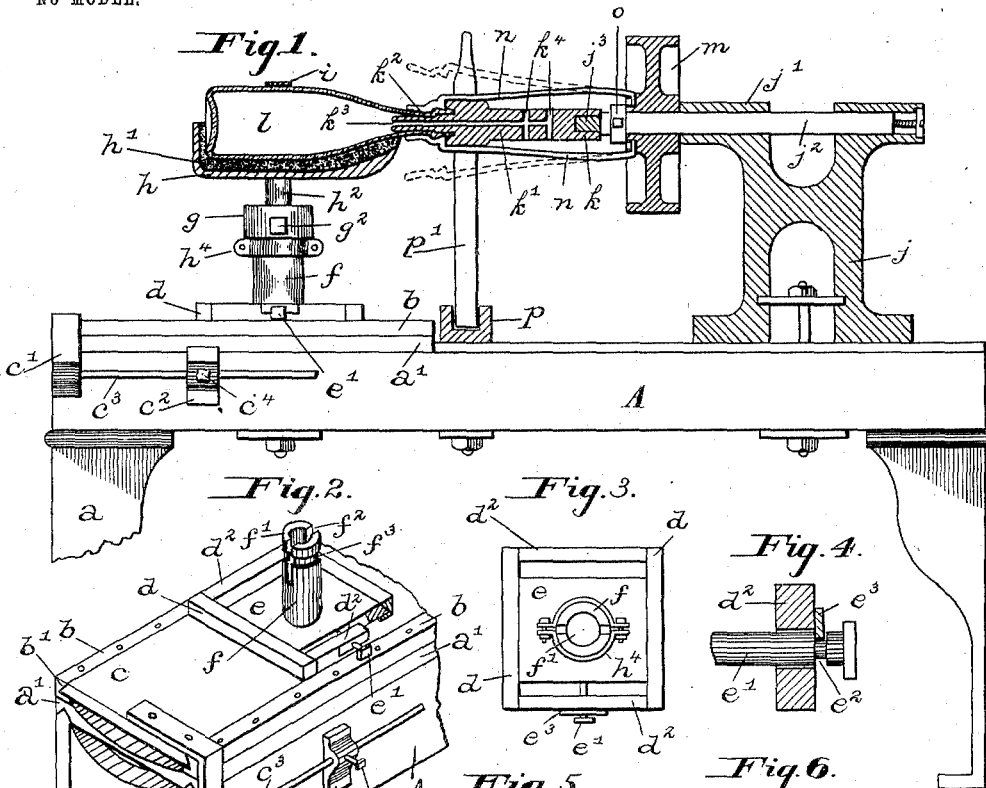

Witnesses.
Samuel Williamson
J. F. Vogt.

Inventor.
Frederick Scheidt
By Mann & Co.
Attorneys.

UNITED STATES PATENT OFFICE.

FREDERICK SCHEIDT, OF BALTIMORE, MARYLAND.

MACHINE FOR FORMING THE NECKS OF GLASS BOTTLES.

SPECIFICATION forming part of Letters Patent No. 760,258, dated May 17, 1904.

Application filed October 21, 1903. Serial No. 177,879. (No model.)

To all whom it may concern:

Be it known that I, FREDERICK SCHEIDT, a citizen of the United States, residing at Baltimore, State of Maryland, have invented certain new and useful Improvements in Machines for Forming the Necks of Glass Bottles, of which the following is a specification.

My invention relates to a machine for forming the necks of glass bottles.

The object of the invention is to provide a simple machine both in construction and operation and by means of which the bottle-necks may be quickly and accurately formed with unskilled labor.

With this and other objects in view the invention is illustrated in the accompanying drawings, in which—

Figure 1 illustrates the machine, part of which is shown in side elevation and part in section. Fig. 2 is a perspective view of one end of the machine. Fig. 3 is a top plan view of the tubular support and the slide on which the same is mounted. Fig. 4 is an enlarged detail of the adjusting-screw for the tubular support. Fig. 5 is a side elevation of the device for clamping the forming-tool around the neck of the bottle. Fig. 6 is an enlarged detail of the pulley and one end of the neck-forming tool and illustrates how the tool is attached to the pulley, and Fig. 7 is a vertical section through the tubular bottle-holder support and the slide on which the same is mounted and illustrates the bottle-holder in place. Fig. 8 is a sectional view through a portion of the bottle-holder, and Fig. 9 is a perspective view of a bottle-neck made by the particular former illustrated.

Referring to the drawings by letters, A designates a table or stand of any suitable construction and preferably supported on legs *a*. On top of the table and bearing at each side thereof is a bed *a'*, and secured to said bed at opposite sides is a guide-strip *b*, provided with a V-shaped groove *b'*, which extends in a direction lengthwise of the table and in which a plate *c* fits and has movement in a direction lengthwise of the machine. Secured to said plate and extending over the top of the guide-strip *b* is a stop-arm *c'*, which in the present instance extends downwardly and parallel to

the side of said table. A bracket *c²* is secured to the side of the table, and in the present instance said bracket carries a rod *c³*, which is adjustable in a lengthwise direction through said bracket by means of a set-screw *c⁴*. This rod *c³*, as shown in the accompanying drawings, extends in a direction parallel with the plate *c*, and its projecting end is adapted to contact with the arm *c'* when the latter and the plate are moved, so as to form a stop against which said arm may abut in order to limit the horizontal movement of the said plate. By means of the set-screw the rod *c³* may be adjusted, so that the plate may be repeatedly stopped at any desired point. On top of the plate and extending in a direction crosswise thereof are two parallel guide-strips *d*, each of which is provided with a V-shaped groove *d'*, and at each end said guide-strips are connected by a cross-bar *d²*. It will thus be seen that the two strips *d* and cross-bars *d²* form practically a square frame on top of the plate *c*, as plainly seen in Fig. 3.

A slide-block *e* is mounted within the frame on top of the plate *c* and has its edges fitting in the grooves *d'* of the guide-strips *d*, so that said block may be moved in a crosswise direction on top of the plate. In order to provide for a delicate adjustment of this block with respect to said plate, I provide a screw *e'*, having a circumferential groove *e²*, and a plate *e³*, having a semicircular notch. The screw passes freely through the cross-bar *d²* and screws into the block *e*, and the plate *e³* is secured to the outside vertical wall of said bar, and the notch takes in the annular groove *e²* of the screw and likewise prevents movement of the latter. As the screw is turned the block will be moved in a horizontal plane crosswise of the plate.

On top of the block *e* is a vertical tubular support *f*, which is secured to said block in any suitable manner, and said support is provided with a smooth central bore *f'* and vertical slots *f²* at diametrically opposite sides, which in the present instance extend vertically to the top of said support. Near the top this tubular support is also provided with a circumferential groove *f³* for a purpose to be presently described. A cap *g* fits over the

top of said tube and is provided with a central threaded hole g' , and a set-screw g^2 extends through the vertical flange of said cap and takes in the annular groove f^3 of the tubular support. By this construction it will be seen that the cap may be turned freely in a horizontal plane, but is prevented from rising by means of the screw g^2 taking in said groove. It is also apparent that by turning the screw so as to bind in said annular groove the cap may be rigidly secured on top of said support.

A bottle-holder h comprises a receptacle for a bottle, having a lining of asbestos h' and a vertical threaded stem h^2 , which passes down through the threaded opening g' of the cap and projects freely into the central bore f' of the tubular support. The stem h^2 of said holder is provided with two pins h^3 , which project into the vertical slots f^2 of said support and prevent rotation of the said stem. In order to vertically adjust said stem and bottle-holder, it is only necessary to rotate the cap g , which obviously will impart a vertical movement to said stem and holder, and when the same have been properly adjusted the set-screw g^2 may be turned to rigidly hold the cap and stem in the adjusted position. It will therefore be seen that the bottle-holder h may be adjusted in three different directions—lengthwise by the movement of the plate e , crosswise by the movement of the block e , and vertically by the rotation of the cap g . As an additional clamping means to insure that the stem and bottle-holder may be rigidly secured I provide two semicircular clamping-rings h^4 , which take around the tubular support and when drawn together by means of suitable bolts bind the two sections of said support together around the said stem. The bottle-holder is also provided with an arm i , which is adapted to take over the body of the bottle and secure the same in position in the holder.

The description thus far relates to the bottle-holder and the devices for adjusting same in a vertical, horizontal, and longitudinal direction. This portion of the invention is important, as it enables the holder to be adjusted in any desired direction to accommodate any size bottle on which the neck is to be formed, so that the neck of the bottle may be presented to the neck-forming tool, which has a given position. The tool and mechanism for operating same will now be described.

On top of the table A and at one end thereof is a vertically-extending head j , which has horizontal movement thereon and is provided at its upper end with a bearing j' , in which is supported a stationary horizontal shaft j^2 . This shaft is provided with a screw-threaded end j^3 , which enters an internally-threaded socket k in the end of the stationary mandrel k' . This mandrel is to form the interior of the bottle-neck, and its neck-forming end k^2

is exteriorly shaped in any desired manner to suit the requirements of the neck desired, and at said end the mandrel is provided with a central passage k^3 , which extends longitudinally from said end toward the stationary shaft j^2 and terminates in the passages k^4 , which extend through the mandrel at right angles to said passage k^3 . By means of these passages k^3 and k^4 the air in the bottle l is permitted to escape. On the exterior of the stationary shaft j^2 and adjoining the bearing j' is a pulley m , which turns loosely on said shaft, and the hub of said pulley at one side is provided with an annular reduced portion m' .

The neck-forming tool of any of the well-known constructions has two spring-formers n for shaping the exterior of the neck, and the ends of said formers are turned inwardly toward each other and fit against the face of the annular reduced portion m' on the hub of the pulley m . A collar o surrounds the shaft j^2 between the ends of the spring-formers and serves to prevent horizontal movement of the pulley m .

Secured on top of the table beneath the spring-formers n is a bracket p , which is also movable horizontally, and two clamps p' are pivoted at their lower ends to said bracket, and near their upper ends said clamps are each provided with a circular portion p^2 , which surrounds said spring-formers n and by means of which the said formers as they revolve may be contracted and brought into contact with the neck of the bottle and form the neck as they revolve.

The operation is as follows: A bottle having its neck portion heated and in condition to be shaped is placed in the holder h on the asbestos lining, with the neck pointing toward the mandrel k' . The plate e is then moved, carrying the bottle-holder and bottle with it toward the mandrel until the arm c' contacts with the end of the rod c^3 . This movement of the plate causes the interior of the neck of the bottle to fit over the end of the mandrel and the exterior to take position between the spring-formers n . The clamps p' are then drawn together around the said spring-formers and contract the latter and cause the same to contact with the exterior of the bottle-neck. As the formers revolve and are gradually drawn together, it will be seen that the shape of the former will be impressed in the neck, and this operation is continued until the neck is the proper size and form. When the clamps are released, the spring-formers expand, so as to draw away from the neck and the bottle-holder, and the plate is moved backward or away from said mandrel.

Having thus fully described my invention, what I claim as new, and desire to secure by Letters Patent, is—

1. In a machine for forming the necks of bottles the combination of a mandrel; a revolvable former; a bottle-holder provided with

a support; means for adjusting said support and bottle-holder in a vertical direction with respect to said mandrel, and means for adjusting said support in a crosswise direction also with respect to said mandrel.

2. In a machine for forming the necks of bottles, the combination of a table; a plate on said table and movable longitudinally thereon; a slide-block on said plate and movable there-
 10 with but having movement in a crosswise direction independently of said plate; a bottle-holder supported above said block and movable therewith; a mandrel; a former and means for revolving said former.

3. In a machine for forming the necks of bottles, the combination of a table; a plate on said table and movable longitudinally thereon; an arm on said plate; an adjustable stop device adapted to contact with said arm; a bottle-
 20 holder mounted so as to move with said plate; a mandrel and a revoluble former.

4. In a machine for forming the necks of bottles, the combination of a stationary mandrel; a former revoluble around said mandrel;
 25 a bottle-holder movable with respect to said mandrel, and a clamping device comprising two vertical arms each of which is provided with a circular portion which surrounds said revoluble former to clamp the same around
 30 the bottle-neck.

5. In a machine for forming the necks of bottles, the combination of a table; a bottle-holder supported above said table; a pulley revoluble above said table; a former compris-

ing two spring-arms which are attached at one end to the hub of said pulley and revolve therewith, and a stationary mandrel around which the former revolves.

6. In a machine for forming the necks of bottles, the combination of a table; a bottle-
 40 holder supported above said table so as to be adjusted in a vertical, longitudinal and also a crosswise direction; a stationary horizontal shaft; a pulley revoluble on said shaft; a stationary mandrel; and a former attached to
 45 and revolving with said pulley and around said stationary mandrel.

7. A machine for forming the necks of bottles, the combination of a table; a bottle-holder supported above said table so as to be adjusted
 50 in a vertical, longitudinal and also a crosswise direction; a stationary shaft also above said table and supporting a stationary mandrel at one end; a pulley revoluble around said stationary shaft and carrying a plurality of form-
 55 ers; a bracket adjustably mounted on said table and pivotally supporting two vertical clamp-arms each of which latter is provided with a circular portion which surrounds the
 60 formers whereby to contract the latter as they revolve around the bottle-neck.

In testimony whereof I affix my signature in the presence of two witnesses.

FREDERICK SCHEIDT.

Witnesses:

ROBERT C. RHODES,
 G. FERDINAND VOGT.